

CHEMICAL ENERGY SYSTEM FOR CLOSED-DOOR EAF STEELMAKING

JetBOx™

increased efficiency

improved safety

higher yields and productivity

The PTI JetBOx™ is the latest development in the field of integrated chemical energy systems for the electric arc furnace.



JetBOx™ Technology

"With lateral thinking we can deliver improved productivity, greater efficiency and faster payback."

Jaroslav Brhel
Ferrous Sales Manager, Air Products

Chemical energy system for closed door EAF steelmaking

Air Products has been a leading supplier to the European iron and steel industry for over 50 years. Air Products has joined forces with Process Technology International Inc. (PTI), a leading supplier of combustion equipment to the US steel industry. Together we are bringing the proven JetBOx™ technology to steel makers in Europe, the Middle East and North Africa.

Air Products can supply technical and design expertise and advice, process equipment, fully integrated control systems, turnkey installation and commissioning, industrial gas supply and maintenance contracts.

**Air Products solutions
and services:***Technical and
design expertise**Advice and consulting**Process equipment**Fully integrated
control systems**Commissioning**Optimisation**Safety training**Maintenance contracts**Industrial gas supply*

JetBOx™ Technology

Reference Guide

PTI JetBOx™ Technology

The PTI JetBOx™ is the latest development in the field of integrated chemical energy systems for the electric arc furnace. It delivers the highly efficient injection of supersonic shrouded oxygen, natural gas and carbon from multiple sidewall positions. JetBOx™ also offers an optional dust injection system adjacent to the oxy-fuel flame and an advanced control system with foamy slag quality analyser.

The JetBOx™ technology consists of:

- PTI Jet burner - a multi-functional oxygen/gas injector
- Water-cooled copper box for optimal location of the PTI Jet burner (US Patent 6299035, additional patents pending. European patent pending).
- Integrated carbon injection lance
- Alternative integrated solids lance
- Valve trains for oxygen and gas
- Integrated control system for safe, automated operation
- FOMAL - foamy slag quality analyser.

PTI Jet Burner

The Jet Burner's innovative design features an accurate "built-in" oxygen distribution control. This enables flexible switching from one operating mode to another with only one oxygen connection to the burner/injector.

This unique feature substantially reduces the installation and maintenance cost of the system.

Water Cooled Copper Box

The efficiency of the energy injection system is greatly influenced by the location of the oxygen/gas and carbon injection points inside the furnace shell.

The key feature of the innovative JetBOx™ design is that it enables the injectors/burners to be positioned at an optimal attack angle (45°) and closer to the bath surface. This means that when the jet reaches the metal line, it is more stable and at a higher velocity than if it were positioned further away.

This allows for deeper penetration of the metal, giving faster rates of reaction. A further, significant advantage is the cooling effect of the box on the refractory, which prevents potentially higher refractory wear in the hot oxygen reaction zone.

The durable JetBOx™ construction resists the harsh furnace environment, scrap impact and protects the burner tip, even if relatively heavy scrap is used.

Carbon and Solids Lances

The water-cooled copper box provides two integrated lances for solids injection. The lower lance is used for carbon injection and the upper lance can be optionally used for filter dust recycling or for efficient injection of other solids such as pulverised lime. The box provides protection and cooling, so that no additional natural gas lance cooling is required.

The proximity of the carbon, solids and oxygen to the slag/metal intersection provides optimum injection efficiency, without clogging. The carbon, solid and oxygen injection rates are accurately controlled, and are automatically varied according to process requirements. Up to 60 kg/min of carbon can be injected through each JetBOx™ position via a 1½" lance.



Hot Fire Scrap preheating and melting



Soft Lance Scrap cutting with rigid oxygen stream. Post combustion with soft oxygen.



Shrouded supersonic lance Decarburisation, energy introduction and bath agitation.

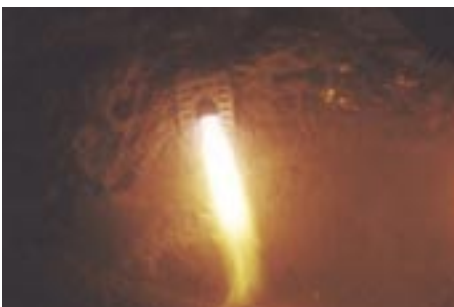

Slag coverage The JetBOx™ promotes good slag coverage which in turn guarantees long water-cooled panel life.

Key Features

- Optimal location of oxy-fuel flame for improved heat transfer efficiency
- Shrouded supersonic oxygen and shorter jet travel, for deeper penetration and improved decarburisation
- Optimal carbon injection angle for greater carbon efficiency
- Multiple oxygen lancing locations
- Closed door operation
- Robust design for high reliability and longer life
- Foaming slag quality analysis

Key Benefits

- Improved safety
- No consumable pipe or lance tips required
- Increased efficiency
- Reduced variable cost
- Higher yields and productivity
- Faster return on investment
- Automatic operation

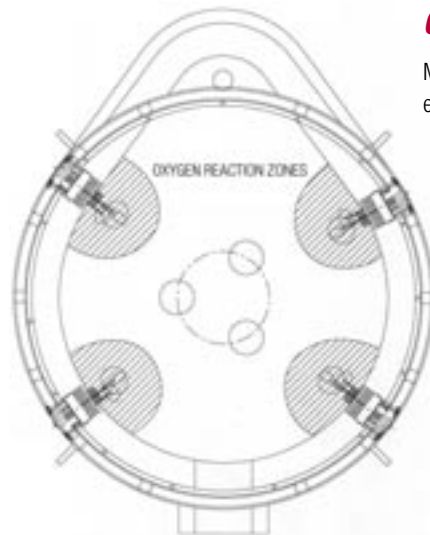

Oxygen Reaction Zones

Multiple reaction zones ensure uniform chemical energy distribution and improved efficiency

Key Elements

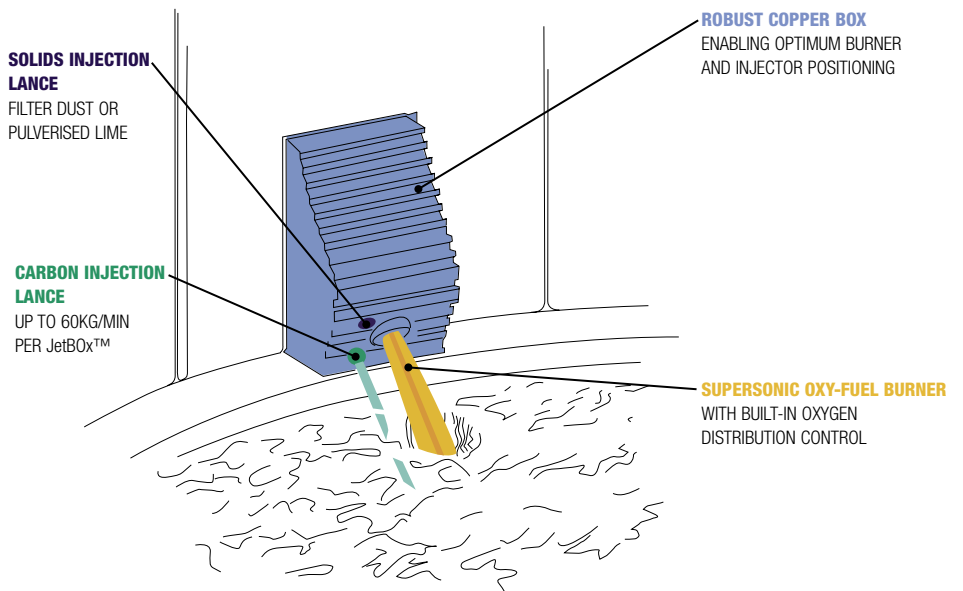

**Air Products solutions
and services:***Technical and
design expertise**Advice and consulting**Process equipment**Fully integrated
control systems**Commissioning**Optimisation**Safety training**Maintenance contracts**Industrial gas supply*

JetBOx™ Technology

Reference Guide

Valve Trains

The flow control valve train provides individual control of natural gas and oxygen flows to each JetBOx™ position. The carefully selected valves are highly reliable, typically requiring little maintenance once operational.

The train is built to Air Products' exacting technical and safety requirements and according to European Codes of Practice. Air Products has been recognised by EIGA for its leading safety performance.



The oxygen/gas valve train is safe, compact and reliable.

Integrated Control System

The integrated control system is designed to provide simple, reliable operation.

The system regulates the flow of oxygen, gas and optionally, carbon and solids injection. In addition, it provides all the necessary safety and shutdown functions.

The operator interface is a user-friendly flat screen, displaying the necessary process information and allowing the operator to change the operating mode of the burners as required.

JetBOx™ can run in fully automatic or manual mode. The PLC type can be selected according to the individual customer's standards.

FOMAL - Foamy slag quality analyser

The JetBOx™ system is supplemented with an EAF power system analysis package that is used to generate a foamy slag index. The package includes the required hardware and software to analyse the EAF current waveform's harmonic content and generate a slag quality signal. This signal is available to the operators and can then be coupled to the carbon injection system for closed loop control of the foamy slag.

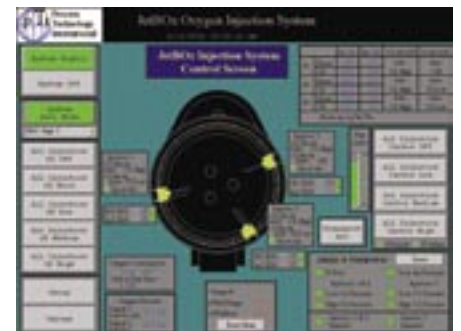

tell me more
[www.airproducts.co.uk/
metals](http://www.airproducts.co.uk/metals)

United Kingdom

Air Products PLC, Commercial Technology Group, Fourth Avenue, Crewe, Cheshire CW1 6XL
Tel +44(0)1270 506000