

PRISM[®] VSA Oxygen Generation Systems

EXPERIENCE AND UNDERSTANDING. THESE ATTRIBUTES ALLOW AIR PRODUCTS TO RELIABLY DELIVER A COST-EFFECTIVE OXYGEN GENERATOR SOLUTION TO MEET THE NEEDS OF YOUR APPLICATION.



| reliable oxygen supply solutions |

As an innovator in adsorption-based air separation systems, Air Products' PRISM VSA Oxygen Generators provide dependable oxygen supply to meet a broad range of requirements, from as little as 100Nm³/hr to more than 20,000 Nm³/hr at purities up to 90%-93%. Our robust PRISM VSA Oxygen Generators offer a highly reliable oxygen supply at an overall cost savings compared to trucked-in liquid. The systems' modular approach facilitates easy installation and maintenance, while the standard features enable the systems to meet the specific needs of glass, nonferrous metals

and steel, cement, pulp and paper, water treatment, refinery, renewable energy, and other industries.

The PRISM VSA Oxygen systems generate oxygen using a proprietary molecular sieve which maximizes efficiency and significantly reduces energy requirements, often making this the low-cost oxygen source. With more than 25 years of experience, our technical experts will collaborate closely with you to select the optimal gas supply solution for your application.



Air Products' experience and understanding deliver a Vacuum Swing Adsorption (VSA) solution to supply your oxygen needs:

- **Proven technology** = *Long-term, reliable, economical oxygen supply*
- **Advanced air separation process** = *Lower power requirement*
- **Packaged plant design** = *Quick installation at the job site*
- **On-site gas production** = *Reduced carbon footprint*

PROCESS DESCRIPTION

Unlike cryogenic air separation process, the VSA generator works at ambient temperature significantly reducing power and capital investment.

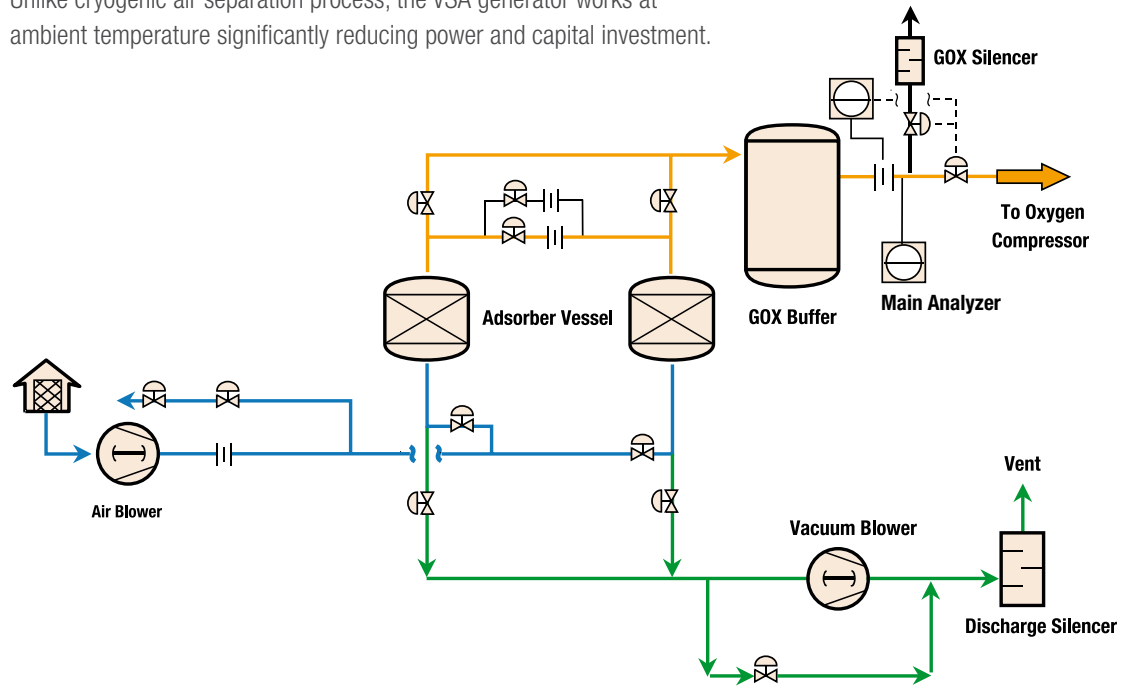

| process description |

SUPERIOR DESIGN DELIVERS PERFORMANCE

The PRISM VSA Oxygen Generator uses adsorption technology to separate atmosphere air into its two principal components – nitrogen and oxygen. Oxygen, at your specified purity, is provided to your application at the required pressure, and the waste stream (impure nitrogen, water and carbon dioxide) is vented to the atmosphere. Utilizing a fully automated batch process, the VSA's molecular sieve adsorber vessels alternately pressurise to produce oxygen, then depressurise, regenerate and purge to be ready for the next cycle. Uninterrupted, consistent oxygen flow to your application is maintained by a product buffer tank which stores oxygen to ensure supply at all times during the operating cycle. Unlike cryogenic air separation processes, the VSA generator works at ambient temperature, significantly reducing power consumption and capital investment.

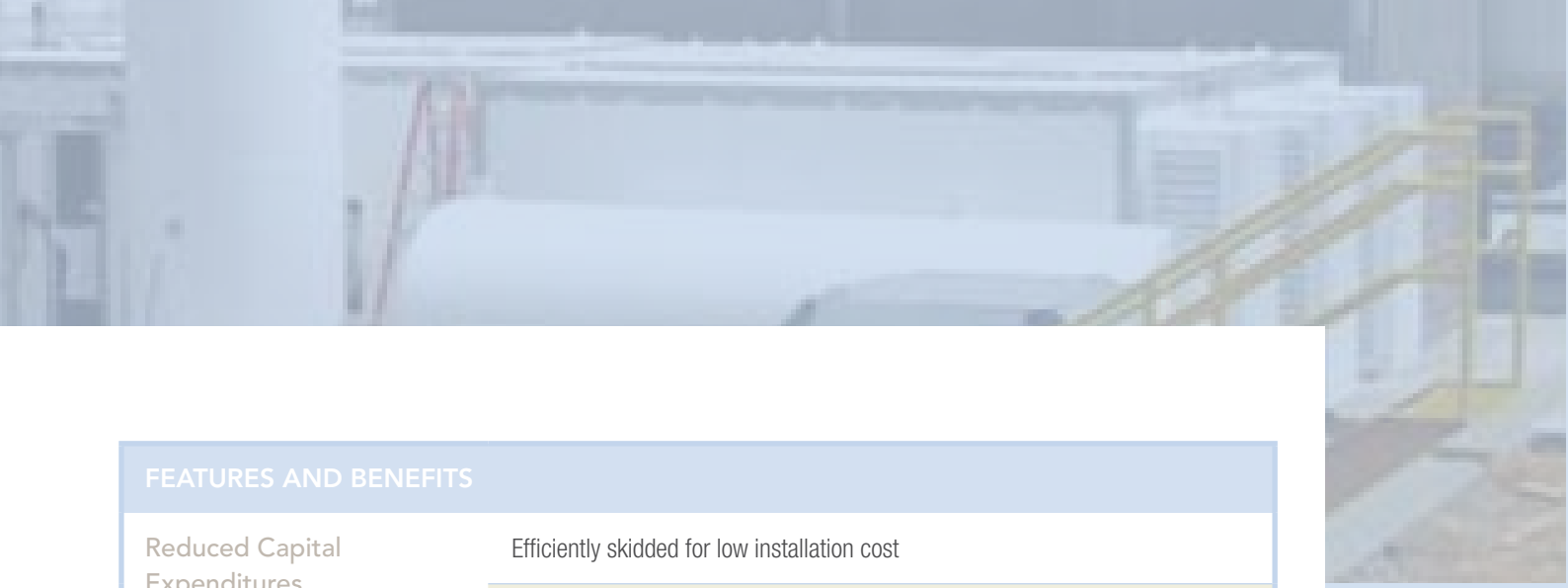

FEATURES AND BENEFITS

Reduced Capital Expenditures

Efficiently skidded for low installation cost

Modular design for easy relocation

Minimum required plot space

Lower Operating Costs

Operating cost savings within turndown range

Power-efficient gas supply

No utility water required for base VSA

Designed for unmanned operation

High Reliability

Fully automatic controls

Monitoring 24/7

Full local and remote control

Flexibility

Efficient turndown to 50% of full capacity

Advanced sound abatement

Specific industry focus with superior integration of supply

Customisable Options

Oxygen booster compressor systems with closed loop cooling skid

Stand-alone instrument air supply

Reduced voltage start-up

Fully enclosed building for increased sound abatement

Tight pressure control

Flexible layouts

| utilities required |

PRISM VSA OXYGEN GENERATION SYSTEMS

Instrument Air

Electric Power 380-480 VAC, 3 pH, 50-60 Hz Low to Medium

Siting Requirements Class 1 Division 2 Group B (main skid); Unclassified (control area)

Controls Intrinsically safe or Class 1 Division 2 Group B inside main skid (24VDC)

| worldwide |

GLOBAL EXPERTISE DELIVERED LOCALLY

With local expertise around the world, Air Products is focused on delivering reliable, cost-effective gas supply solutions based on understanding your needs. Contact your local representative to see how we can help you.

Europe

Air Products PLC
2 Millennium Gate
Westmere Drive
Crewe
Cheshire CW1 6AP
United Kingdom
Tel +44(0)800 389 0202
Email apbulkuk@airproducts.com

**For local contact information
please check the Air Products
country webpages*



tell me more
www.airproducts.com/gasgeneration