

Pilkington and Air Products

New horizons in Russia



GAS ESTUDY





“With all the real and perceived risks of the Russian market, the people at Pilkington were looking for a partner they could feel comfortable with – not just a gas supplier.”

Gavin Whitlock, European marketing manager, Generated Gases, Air Products



Destination Moscow

When glass manufacturer Pilkington needed supplies of nitrogen, hydrogen and compressed air for a new world-scale float glass factory near Moscow, the company turned to long-time business partner Air Products for help. The result – a plant of outstanding reliability achieved under demanding working conditions – has been a success story for all concerned.

Reliability was one of the most important requirements for the new gas plant. Since Russia does not yet have an extensive infrastructure for industrial gases, it was essential that the on-site gas plant would be self-sufficient in the production of liquid nitrogen.

Air Products met Pilkington's reliability concerns through a combination of technical and commercial benefits.

Equipment redundancy and a plant design that is entirely self-sufficient minimise the risk of an unplanned shutdown. On the commercial side, a long-term supply contract provides Pilkington with guaranteed gas supplies and security of supply within a defined contract structure.

Air Products owns, operates and maintains the gas plant, so Pilkington can concentrate on its core business of glassmaking and leave the gas supply to the experts. Though onsite agreements like this one are still a novelty to Russian companies, Air Products is confident that their commercial advantages will ensure rapid acceptance in this growing market.



Glass companies expect highly reliable equipment to help make glass efficiently. With the Air Products Glass Technology solution, that's exactly what they have. As one Pilkington employee was heard saying, "That's a glass maker's plant"

Pilkington looks East

Developing markets like Russia are key to Pilkington's future business strategy. The company has supplied the Russian market through sales offices since 1996, and by 2002 had decided to build a world-class float glass plant in the Moscow area. Construction began in summer 2004, and the plant was commissioned in winter 2005. Capacity is 240,000 tonnes/year.

The new plant is near the city of Ramenskoye, around 35km south-east of Moscow. Ramenskoye itself is a centre for textiles and engineering, as well as a residential suburb of Moscow. The 37ha plant site, outside the city, is located near a quarry that supplies good glassmaking sand.

The manufacture of float glass needs a protective atmosphere of pure, dry nitrogen and hydrogen to prevent oxidation

of the bath of molten tin on which the glass sheet floats. Mike Hevey, European Business Manager: Metals, Glass and Minerals says, "Gas quality and continuity of supplies is critical to such a sensitive process. An interruption in supply or off-spec gas can have a detrimental effect on glass quality, resulting in the loss of production at potentially great expense. Our experience in the glass industry together with a high-quality innovative solution specifically for the float line industry, meant we were well placed to meet and exceed the expectations of Pilkington, who are themselves leaders in flat glass production."

A well-tested collaboration

Pilkington and Air Products have worked together for many years, and Air Products supplies nearly half of Pilkington's gas requirements worldwide.

Air Products won the gas supply contract for the Ramenskoye plant after a lengthy bidding process. "The bid was a global effort, involving groups from the UK, Canada and the USA, and from Operations, Commercial Technology, Engineering and Sales," says Dimitri Wittevrongle. "Right from the start we could see that Pilkington's concerns were plant reliability, low winter temperatures, and our ability to manage and optimise the plant remotely. Our technical capabilities, operating reliability and infrastructure enabled us to show Pilkington that we could meet their needs in this new region."

On the key question of building and operating air separation plants in cold weather, Air Products was able to point to two of its plants designed for even more

extreme winter conditions than at Ramenskoye. An air separation plant that Air Products operates in Yellowknife, Canada, is 400km south of the Arctic Circle at latitude 62°N, compared to Rameskoye's location at 55°N. Another plant, built for Syncrude in Alaska, is just 100km south of the arctic circle and sees winter temperatures down to -40°C.

The two companies agreed that Air Products would build an on-site cryogenic plant producing 18,500 tonnes/year of high-purity nitrogen, plus compressed dry air (CDA) to operate the glass plant's pneumatic systems. There is also a separate electrolysis unit with a capacity of 85 tonnes/year of high-purity hydrogen. Air Products' total investment in the gas plant was around \$10m.



Designing for peace of mind

Reliability and independence from external services were key issues in the selection of the gas plant. With this in mind, the two companies decided to use a plant design that produces nitrogen in liquid as well as gaseous form. Storing liquid nitrogen on site allows the plant to be started up without the need for external liquid nitrogen supplies, and contributes to the plant's overall reliability of 100% by providing back-up during both planned and unplanned shutdowns.

Redundancy in key components increases the plant's reliability. "A typical on-site cryogenic nitrogen plant has a single compressor," says Air Products project manager Andy Cocksedge, "but for this job, we used redundancy to compensate for the lack of infrastructure in the region. At Ramenskoye we have three

main air compressors, each able to meet 50% of the average demand, and 100% redundancy on the compressed air dryers. There's also a dedicated standby compressor for the CDA, and the gas plant has its own diesel generator in case of power failures."

"Flexibility is one of the benefits we can bring to Russian industrial gas customers," adds Katrin Michaels, Air Products marketing manager for Russia. "Russian-built cryogenic plants are available, but they tend to be very standardised, and based around machinery rather than service. We offer better and more modern technology, and we are also better at customising the plant to suit the customer – both in a technical sense and in terms of the alternative business models. So really our customers get the best of all worlds."

Braving the cold

Construction began early in 2004, bringing together staff from three Air Products locations: the Moscow office; the company's European headquarters at Hershham, UK; and Prague, the base for Air Products' operations in central and eastern Europe.

"There was never any doubt that we could meet the technical requirements for the plant, but making it work in Russia was always going to be challenging," says Cocksedge. One of the main issues was

how to communicate with local contractors, since even in the Moscow region many people do not speak English. "Our Russian speaking staff were crucial here due to their understanding of local culture and business practices," he explains.

With average winter temperatures of -25°C and no prospect of a thaw until April or May, site work was challenging. A heated building measuring around 40m x 20m houses the compressors and other sensitive equipment. Large items such as the cold box and liquid nitrogen storage tank are sited outside. Since these are designed for cryogenic temperatures, winter cold was not a problem; the only design modification needed was to make the cold box frame from low-temperature steel instead of ordinary carbon steel. "Air Products used best practice and experience gained working in extreme climates throughout North America to deliver what we had promised to Pilkington," says Cocksedge.

By late summer, construction was well advanced and Air Products was ready to bring in the largest single equipment item, the liquid nitrogen storage tank. This was an epic journey: from a fabrication yard in the Czech Republic, up the river Elbe to Hamburg, by sea to St Petersburg, by river to Moscow, past the Kremlin and finally by road to Ramenskoye.



Local customs

Russian paperwork, from customs to technical approvals, can be frustrating to western companies unused to the experience. “Customs clearance was complex, and there are a lot of inspections to make sure imported equipment meets Russian safety standards,” says Cocksedge. “Understanding the process is half the battle. We chose specialist companies in Russia and the Czech Republic to help us prepare the documentation required. The experience certainly puts us in a great position for future projects.”

For the next project, says Cocksedge, Air Products will be able to draw on experience and local contacts to streamline the construction process. “We will certainly use more local contractors and more locally-sourced equipment in the future, and that will help to keep costs down,” he says. “It takes time to build up good

working relationships with Russian suppliers, but we have made an excellent start. Now we have an office in Moscow, all the necessary pre-qualification of contractors and vendors can be done locally.”

Understanding the local culture is part of doing business in any new territory, and Air Products’ attention to detail allows the company to meet every requirement of the Russian system. “We have shown that we can work successfully in Russia, building and operating a plant that’s appropriate to the local conditions,” says Gavin Whitlock, european marketing manager, Generated Gases with Air Products. “We foresee plenty of new business from western companies operating in Russia, and from Russian companies too, once they realise the advantages we can offer in nitrogen and oxygen plants of all sizes.”



Don't buy a plant, buy gas

Under the onsite contract at Ramenskoye, Pilkington does not own the gas plant, even though it is located on the Pilkington site. Instead, the gas plant is owned, operated and maintained by Air Products. Air Products sells the nitrogen produced by the plant to Pilkington at fixed prices under a long-term contract.

The onsite system is an example of outsourcing, a concept that works well for western companies but may be less familiar to Russian firms.

As well as saving money, long-term "sale of gas" (SOG) contracts also give customers peace of mind by transferring the operating risk and guaranteeing security of supply. In the unlikely event of the plant becoming unavailable, the gas company will typically supply back-up by road tanker.

Air Products offers on-site generation systems and SOG contracts for nitrogen, oxygen and other gases, in a variety of purities. Quantities cover the range 50-5,000m³/day, depending on customers' requirements.



Czech experience is key

Air Products' experience in the Czech Republic has been important in gaining a business foothold in Russia, says Zdenek Cejka of the company's Prague office, because of the two countries' geographical and cultural closeness. "Anyone who was educated here before 1989 speaks at least some Russian, so it's quite easy for us to communicate with Russian engineers who don't always speak good English," he explains. "Doing business with Russian people is a personal affair: you need to meet them, and preferably speak to them in their own language."

Russian and Czech culture has a certain amount in common, so Czechs may be less inclined than their western European or US colleagues to become frustrated by Russian bureaucracy. "After all, the paperwork is really there to ensure safety," says Cejka. "Most Russian engineers are extremely well qualified, even though some of their equipment is old-fashioned by western standards."

A phenomenon that until recently was unknown to both Czechs and Russians is the onsite contract, under which a gas plant located on a customer's site is owned and operated by a specialist gas company. "Ten years ago this was a new idea to us," says Cejka, "but since Air Products moved into the Czech Republic, Czech companies have been quick to see the advantages. I'm sure the same thing will happen in Russia, so our future business prospects there are very promising."

"And now that Air Products has an office in Russia, there will be less need for direct support from the Czech Republic. The Prague staff are always here as a backup, but in future most commercial and technical matters will be handled directly from Moscow."

Liquid nitrogen on tap

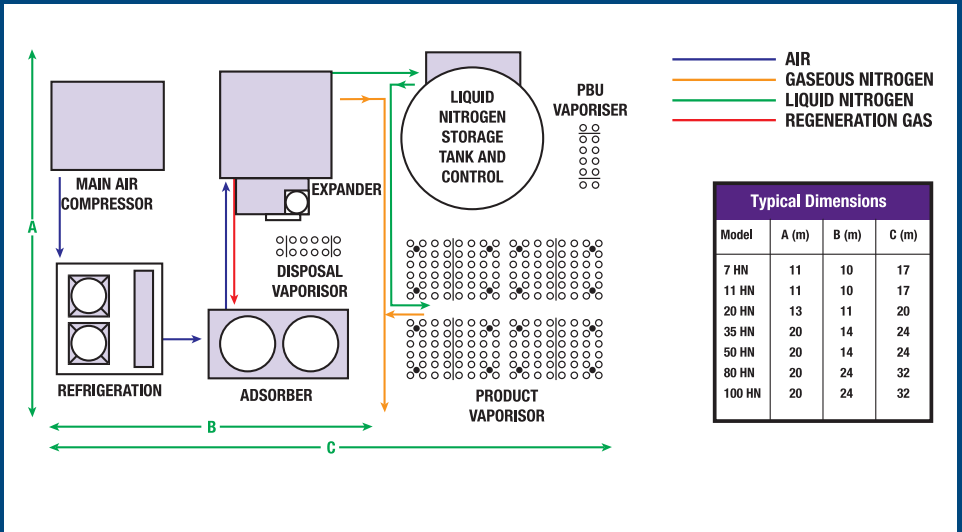

Typical plant layout

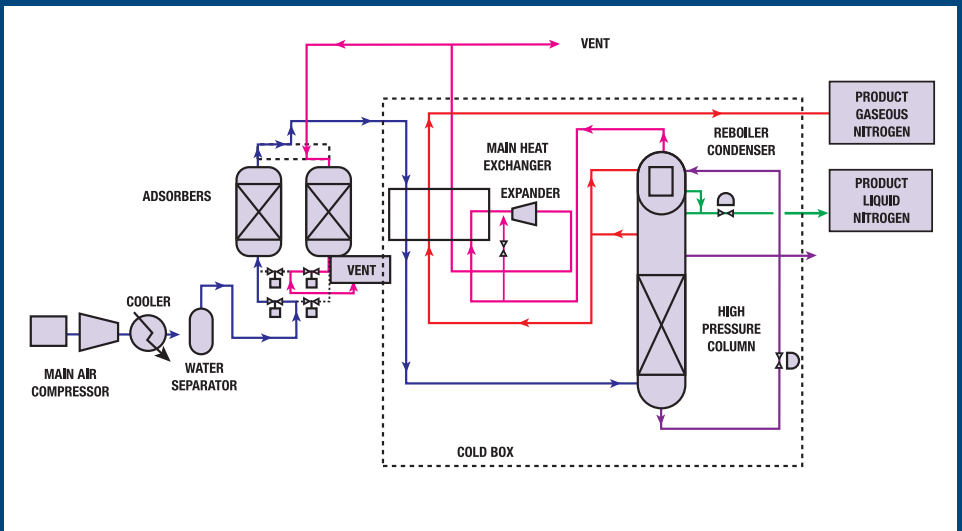

Process flow diagram

About Pilkington

Founded in 1826 and a member of the Japanese NSG group since June 2006, Pilkington is a leader in the global Flat Glass industry. The combined annual sales of NSG/Pilkington are around £4 billion and the newly-enlarged group has ownership or interests in 50 float lines on five continents, with a total annual capacity of around 6.4 million tonnes. NSG Group employs 36,000 employees worldwide, with manufacturing operations in 26 countries and sales more than 130 countries. The Float process, invented by Sir Alastair Pilkington in 1952 is now the world standard for high quality glass manufacture.

Air Products in the glass industry

Air Products, the world's only combined gases and chemicals company, has been a leader in oxy-fuel technology for the glass industry for over 30 years.

Air Products has the technology and expertise glassmakers need to improve their glass melting operations. The high-luminosity, low-momentum Cleanfire® burner is the industry benchmark, with well over 1,000 burners installed today. Customers worldwide have entrusted Air Products with their furnaces and implemented our technology in over 150 furnaces producing more than 7,000 tonnes/day of glass.

By combining this world-leading technology with its expertise in furnace modelling and combustion control systems, Air Products can help glassmakers improve the efficiency of their melting processes and reduce overall costs.

Air Products PLC
Millennium Gate
Westmere Drive
Crewe
Cheshire CW1 6AP
Tel +44(0)800 389 0202
www.airproducts.com/GasGeneration/
www.airproducts.ru

tell me more
www.airproducts.co.uk